

2005G2

OPERATING INSTRUCTIONS

2005G2 Vacuum Hand Pump

July 2008



(Figure 1) Vacuum Hand Pump with Accessories

The 2005G2 Vacuum Hand Pump is a convenient and easily operated vacuum device. It is designed for air and/or water, pulled in at the front and exhausted through the upper side fitting located directly below the handle end of the pump.

Not only will the pump pull a vacuum in short order, but due to the exceptional sealing of the valves, will maintain a large evacuated volume over an extended period of time.

WARRANTY & LIABILITY

Soilmoisture Equipment Corp. (SEC) warrants all products manufactured by SEC to be free from defects in materials and workmanship under normal use and service for twelve (12) months from the date of invoice provided the section below has been met.

Soilmoisture Equipment Corp. (SEC) is not liable for any damages, actual or inferred, caused by misuse or improper handling of its products. SEC products are designed to be used solely as described in these product operating instructions by a prudent individual under normal operating conditions in applications intended for use by this product.

PARTS

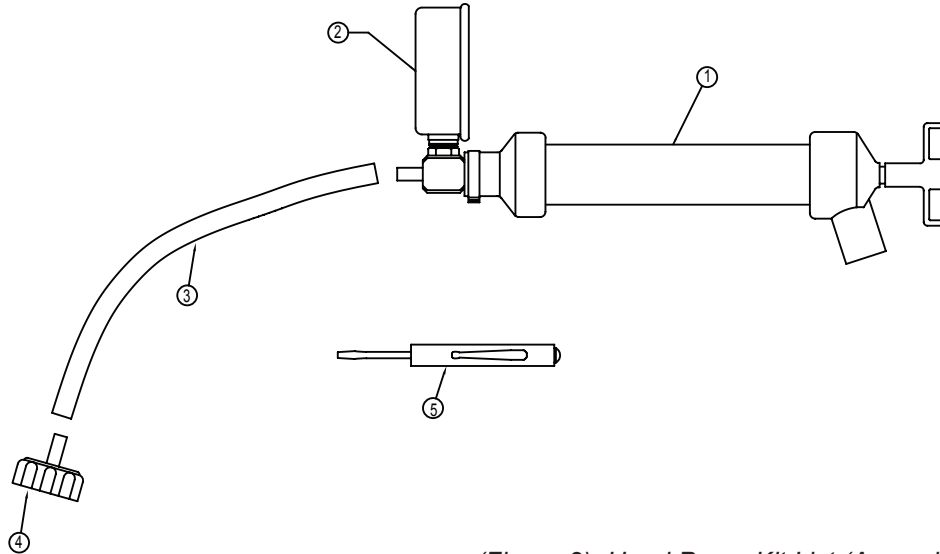

(Figure 2) Hand Pump Kit List (Assembled)

Item #	Part #	Description
1.	MML010	Utility Hand Pump
2.	2060FG3	Vacuum Dial Gauge Recalibrator Style
3.	2005-007	Hose, 3/16" ID X1/8" wall, 2 ft. long
4.	2701-001	Service Cap
5.	2029	Gauge adjusting screwdriver

SPECIFICATIONS

- Capable of developing vacuums to 70 centibars (70 kilopascal)
- Rugged portable design for prolonged use in the field, brass and rugged elastomers.
- Use for air primarily and water
- Each pumping stroke = 86 ml / stroke volume of air or water
- Recalibrator style gauge 0-100 cbar
- Hose and service cap for use with standard Soilmoisture tensiometers

A PUMP WITH MANY PURPOSES

The 2005G2 Vacuum Hand Pump is used for servicing all varieties of standard Soilmoisture Tensiometers; *Model 2710 Soilmoisture Tensiometer*, the *Model 2725 Jet Fill Tensiometers* and all other types that use our quick thread top connections. It can be used for a many other purposes from checking out Soil Water Samplers and evacuating them to work with portable vacuum extraction systems. The pump will find a number of handy uses.

FOR USE WITH OUR TENSIOMETERS

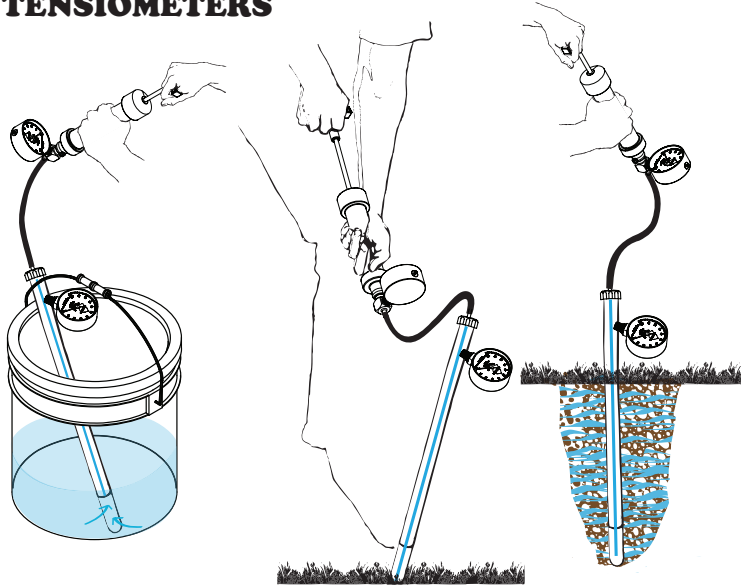

(Figure 3)

Pulling water into the
tensiometer

(Figure 4)

Removing air from gauge

(Figure 5)

Ready for use

As shown in (Figure 3), the first item of business is in pulling water into the tensiometer. First, boil some water (it helps remove the entrapped air), let it cool in a container. Place the tensiometer in the container and create a vacuum in the tensiometer by slowly pulling the handle on the 2005G2 Vacuum Hand Pump. This brings water up through the ceramic cup, through the interior of the tensiometer and finally into the cap. Air will also begin to come out of the gauge. Pull in a bit more water until the big bubbles stop.

Remove the tensiometer from the bucket (Figure 4) and pull a high vacuum of 80 cb. on the hand pump and watch as air comes out of the gauge. Insert back into the bucket and repeat the process of pulling water into the tensiometer. Again, remove the unit and pump and draw another high vacuum to evacuate more air. This “purging” of air from the gauge is an important step in making the tensiometer sensitive to its placement in the soil.

Once installed in the soil, as shown in (Figure 5) on a *Model 2710 Soilmoisture Tensiometer*, remove the cap for a short period of time. This allows water to move out of the unit and into the soil. Attach the 2005G2 Vacuum Hand Pump to your *Model 2710 Soilmoisture Tensiometer*, and once again pull a moderate vacuum, this pulls back some of the water allowed to go into the soil and establishes a good working hydraulic relationship between the soil pore water.

(For more on this procedure consult the instruction manuals for the *Model 2725 Soilmoisture Tensiometer* or *Model 2710 Soilmoisture Tensiometer*.)

FOR USE WITH OUR SOIL WATER SAMPLERS

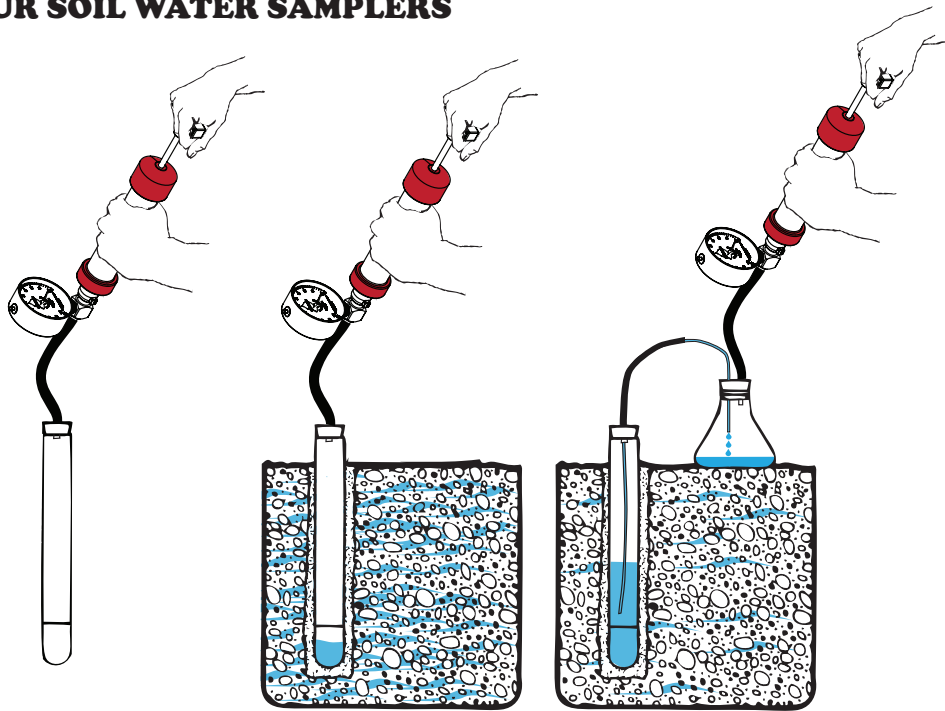

(Figure 6)
Checking the sampler
for leaks

(Figure 7)
Taking a pore water sample

(Figure 8)
Withdrawing a Sample

The 2005G2 Vacuum Hand Pump is essential when working with our 1900 Series Soil Water Samplers as shown above. Prior to (Figure 6), the soil water sampler must be placed in a container of water (letting the ceramic cup wet – 15 min.) Pour the excess water out of the sampler, place the stopper on top of the sampler and connect the hose to the outlet stem of the stopper, use the hand pump to pull a vacuum of 60 cb. on the wetted sampler. The sampler should maintain this vacuum for 7-10 minute period, assuring a leak free assemblage prior to installation.

In (Figure 7) the soil water sampler has been installed and is being prepared to “take a sample”. After pulling a vacuum at 60 kPa (cb), remove the hand pump, place a clamping ring on the tube and leave the sample alone for 24 - 48 hours. The suction within sampler will “pull” in pore water (with a force less than 60 kPa) from surrounding soil pores directly into the sampler.

In (Figure 8) the pore water volume collected by the sampler is being transferred by applying a slight vacuum. The Erlenmeyer flask decants the liquid from the sampler into the flask for later lab analysis.

(If you'd like to know more, consult our installation and instruction manuals for our extensive line of 1900 Series Soil Samplers.)

FOR USE WITH MODEL 2900 QUICK DRAW SOILMOISTURE PROBE

Model 2790U1 Filling Fixture

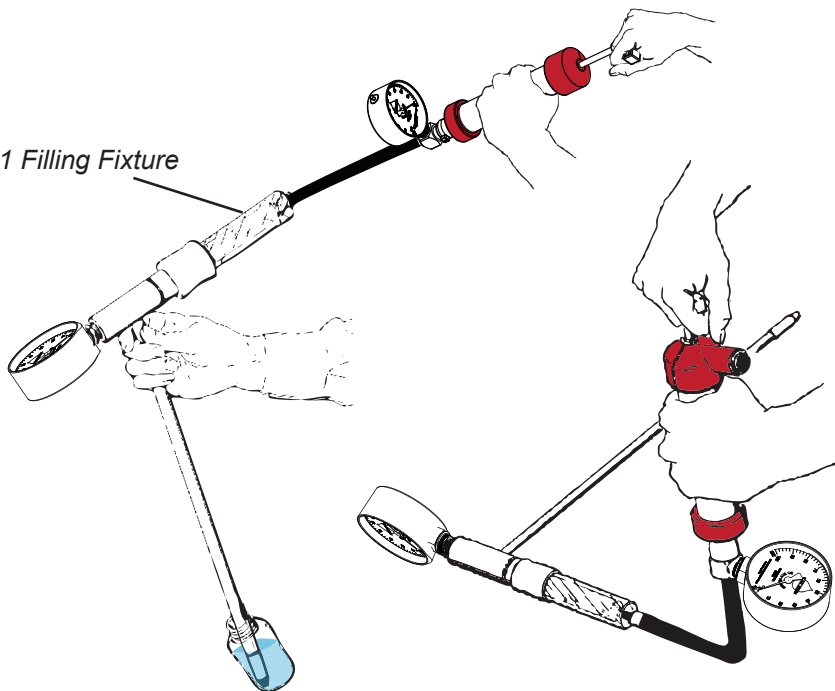

(Figure 9)
Filling the Probe with water

(Figure 10)
Evacuating air from the Probe Gauge

The *Model 2900 Quick Draw Soilmoisture Probe* is a natural when used with the *2005G2 Vacuum Hand Pump*. For this job we recommend the *Model 2790U1 Filling Fixture* used in conjunction with the 2005 pump. The *Model 2790U1 Filling Fixture* allows water to be slowly drawn from the tip up through the internal capillary tubing, the gauge and into the filling fixture. The filling fixture provides a reservoir of water as air is purged from gauge after filling.

As shown with the tensiometer earlier, the *Model 2900 Quick Draw Soilmoisture Probe* (a modified tensiometer) absolutely requires a filling - purging cycle. To accomplish the filling one takes a water container and inserts the porous ceramic tip into the water and create a moderate suction of 40-50 kPa (40-50 cb) at the end of the probe body as shown in (Figure 9).

To purge or remove entrapped air from the probe gauge you need to remove the probe from the water and lay on a flat surface as shown in (Figure 10). A very high vacuum of 80-90 kPa (80-90 cb) is placed on the filling fixture and you will see air as bubbles coming into the water remaining filling fixture. The high vacuum is removed and water from the fixture is taken into the probe. Again, a high vacuum is applied and more air removed. This is done a number of times 5-6 times to remove all the air from the system.

The filling fixture and the hand pump are removed, the probe body filled with water and a null knob (not shown) is then inserted into the fully filled probe body and slowly screwed in as extra water is pushed out the ceramic tip at the end of the probe. A "sensitive" hydraulic probe, properly serviced, when set to 80 kPa with the null knob will go from 80kPa to 0 kPa in less than 3 seconds.

(For more on this procedure please consult the *Model 2900 Quick Draw Soilmoisture Probe* operating instructions.)

FOR USE WITH PORTABLE EXTRACTOR SYSTEM

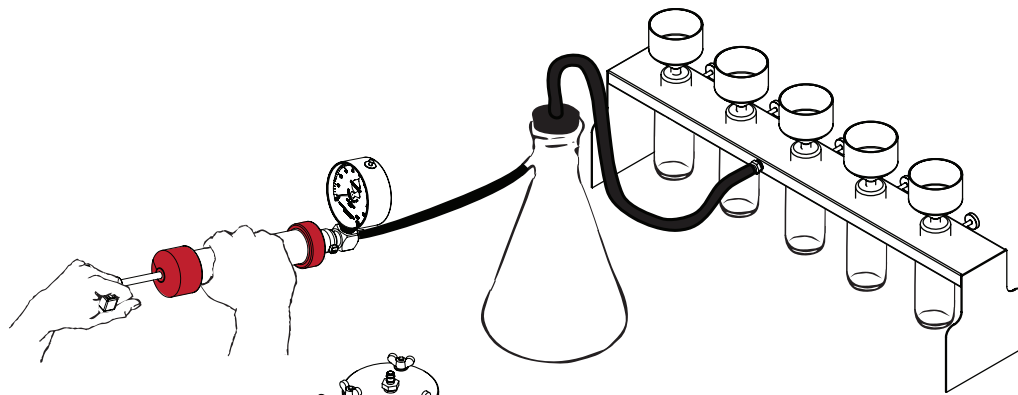

(Figure 11)
Model 1300 Filter Funnel Kit

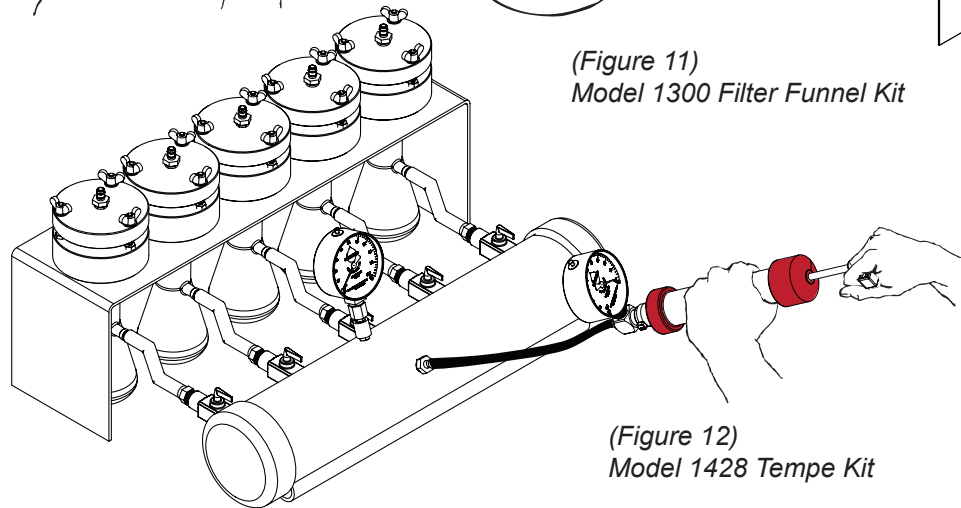

(Figure 12)
Model 1428 Tempe Kit

Whether it's a portable *Model 1300 Filter Funnel System*, as shown in (Figure 11) for "on site" analysis of dissolvable mineral and salt content or (Figure 12) which shows the new *Model 1428 Tempe Kit*, that's used in determining the saturated conductivity or low end release curve information, the *2005G2 Vacuum Hand Pump* will come in handy.

Both systems need a reliable method of creating a partial vacuum of between 5kPa (5cb) to 80kPa (80cb) in any method used. The *2005G2 Vacuum Hand Pump* will produce the required vacuums and assure that the values remain in the sample containers used in the systems. Simply connect the hose and pull the partial vacuum wanted and that's all there is to it.

CHECKING CALIBRATION TENSIO METER DIAL GAUGES USING THE 2005G2 VACUUM TEST HAND PUMP

The *2005G2 Vacuum Hand Pump* should always be kept in mind as a handy calibration device for any and all tensiometers having similar vacuum gauges. When applying a partial vacuum both the hand pump and the device being evacuated should read the same kPa (cb) values assuring that both the instruments are reading correctly in the field. Many times with an early winter frost the gauge bourdon tube can become distended and distorted by water inside freezing. The gauge may look alright but will read poorly or erratic. Using the hand pump as seasonal check for functionality prior to an install is always a good idea.

HELPFUL HINTS AND MAINTENANCE

When the 2005G2 Vacuum Test Hand pump is used for air removal or pulling a vacuum, very little maintenance of the unit is required.

REPLACEMENT PARTS

(Figure 13) 2005G2 Vacuum Hand Pump Replacement Parts

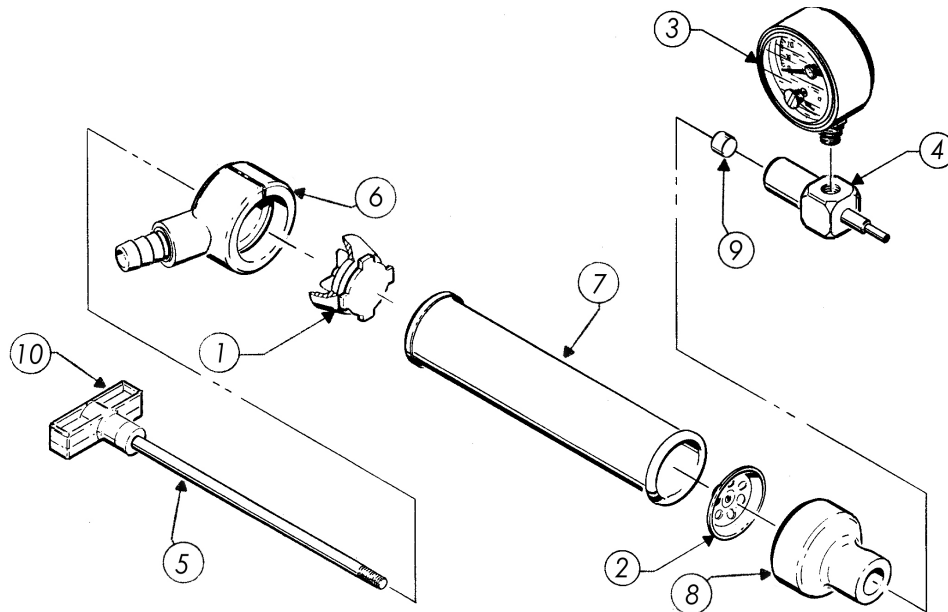

	ITEM PART #	DESCRIPTION
1.	Z2005-003	Plunger valve-assembly
2.	Z2005-004	Intake Valve
3.	Z2060FG3	Vacuum Dial Gauge
4.	Z2005-001	Adapter Fittings
5.	ZMML010-005	Rod
6.	ZMML010-004	Top Cap
7.	ZMMI010-003	Brass Tube
8.	Z2005K1	Intake Cap
9.	ZMML051	Check Valve
10.	ZMM1010-002	Handle

**With dealers throughout the world,
you have convenience of purchase and assurance
of after-sales service.**

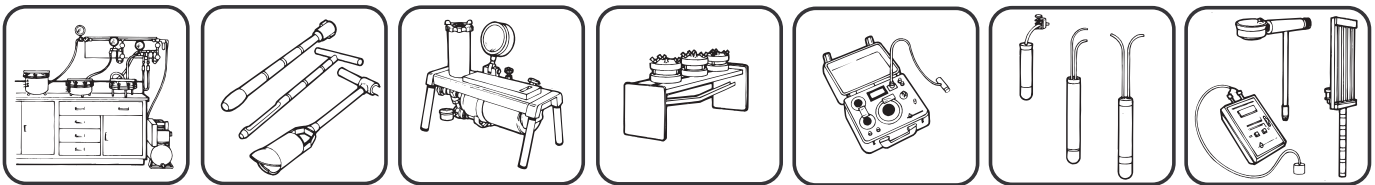

© COPYRIGHT 2008 ALL RIGHTS RESERVED 0898-2005G2